

**NV series**

**Induction VAV air volume control terminals**

**BARCOL-AIR**

# Induction VAV air volume control terminals

## Table of contents

Description	Page
Type designation	1
Technical data	
- General	2
- Specification	3
- Installation instruction	3
Model overview / dimensions	4 - 5
Sound data NVOA00B...	6 - 7
Sound data NVOCO0B...	8 - 9
Sound data NVOG.OB / NVON.OB	10 - 11
Sound data NVOJ.OB / NVOQ. OB...	12 - 13

# Induction VAV air volume control terminals

Type designation  
NV.....

## Composition type designation:

**N - V - O - N - F - O - B**

### **N** Position 1: **Product group**

N = air volume control terminals

### **V** Position 2: **Function**

O = not applicable  
V = VAV Induction terminal  
W = VAV Induction terminal with controlled induction  
1 = non standard, specify separately

### **O** Position 3: **Controls (manufacturer)**

O = without controls  
For controls, contact our sales staff

### **N** Position 4: **Outlet**

O = not applicable  
A = rectangular outlet  
C = 4 circular outlets ('Octopus')  
G = rectangular outlet and provision for integral hot water reheat coil  
J = 4 circular outlets and provision for integral hot water reheat coil  
N = rectangular outlet and provision for integral electric reheat coil  
Q = 4 circular outlets and provision for integral electric reheat coil  
1 = non standard, specify separately

### **F** Position 5: **Reheat coil**

O = without reheat coil  
A = 1-row hot water reheat  
B = 2-row hot water reheat  
D = 4-row hot water reheat  
E = 1-stage 230VAC/1-phase electric reheat coil  
F = 2-stage 230VAC/1-phase electric reheat coil  
G = 3-stage 230VAC/1-phase electric reheat coil  
H = 1-stage 400VAC/3-phase electric reheat coil  
J = 2-stage 400VAC/3-phase electric reheat coil  
1 = non standard, specify separately

### **O** Position 6: **Controls (type & function)**

O = without controls  
For controls, contact our sales staff

### **B** Position 7: **Sensor**

O = not applicable  
B = Flo-cross®, 2 x 12 point averaging and signal amplifying air flow sensor (standard)  
1 = non standard, specify separately

### Ordering example:

N	V	O	N	F	O	B	1	6	0	R	0	5	0	0
See above							Model				Heater capacity			

### Ordering codes "Specials"

N..1... - 3010 = 4 balancing dampers in 'Octopus' outlet  
N..1... - 3006 = 'Octopus' with 6 outlets instead of 4  
N..1... - 3016 = 'Octopus' with 6 outlets incl. balancing dampers  
N..1... - FL = Flange connection 30 mm for rectangular outlet

### Ordering information:

#### Standard terminals:

- quantity of terminals
- complete 7 digit code
- terminal size or model
- air volume setting ( $V_{max}$ ,  $V_{min}$  etc)
- control handing (standard right side)
- if applicable, electric reheat coil capacity

#### Non standard terminals:

- for non standard terminals a full description and / or drawing are requested.

# Induction VAV air volume control terminals

**Technical data**  
**Type (NV.....)**

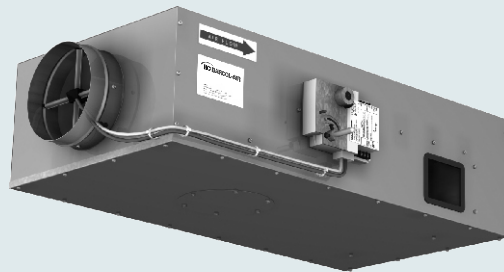

NVOA

## Application

Types NV rectangular pressure-independent VAV air volume control terminals are designed particularly for systems with high variations in heat load. The terminals induce room air and mix it with conditioned primary air, maintaining a nearly constant air volume to the room thus providing sufficient air movement necessary to maintain occupant comfort even in extreme load variations. This specific characteristic means that cold air 'dumping' will not occur and that extremely low primary air temperatures can be used, without producing excessive differences between the supply and the room air temperature. The primary air is controlled by the patented airflow sensor type Flo-Cross®. The Induction VAV terminals can be used for supply air applications in new or refurbishment projects. The terminals can optionally be supplied with a distribution plenum and a built-in hot water or electric reheat coil.

### Features:

- Pressure independent control functions.
- Volume control range 100% to 10%.
- Low pressure loss over the terminal.
- Factory fitted distribution plenum with built-in hot water or electric reheat coil.
- Oval shaped damper blade for linear control characteristics.
- Low leakage damper, less than 1% of Vnom at 750 Pa.
- Low noise level.
- Suitable for all control functions (VAV, CAV, shut-off, etc.) To maximise system energy savings.

- Flo-Cross®, 2 x 12 points averaging and signal amplifying airflow sensor, better than 2.5% accuracy even with irregular duct approach.
- Maintenance free.

## Technical information

### Casing:

Air-tight construction made of galvanized sheet steel with low casing leakage rate.

### Insulation:

The rectangular discharge section is internally insulated.

### Damper:

Damper blade: made of steel, sandwich construction with twin blades and a neoprene gasket with low leakage.

Damper shaft: aluminium,  $\Phi$  12mm with self lubricating nylon bearings.

### Flo-Cross®:

Extruded aluminium construction with nylon core and feet.

### Distribution plenum:

Made of galvanized sheet steel with 13 mm internal isolation. Plenum with standard rectangular or multiple (4 x circular) outlet construction. Optional 1,2,3 or 6 circular outlets are possible. Outlet spigots are made of galvanized steel and optionally can be provided with volume control dampers.

### Reheat coil:

Choice of 1, 2 or 4-row hot water reheat coil or electric reheat coil (230VAC/1-phase or 400VAC/3-phase).

### Controls:

Suitable for use with pneumatic, analogue electronic or DDC controllers. Controls can be factory fitted, wired and calibrated. Controls enclosure (galvanized sheet steel) can be provided optionally.

## Delivery format:

### Delivery format:

- The VAV or CAV terminal will be supplied as a single mounting assembly. Optional ordered distribution plenum, reheat coil and/or controls are factory fitted, wired and calibrated. The terminal can be directly installed and commissioned when delivered to site.
- Controls location and hot water or electric connections are as standard fitted on the right hand side of the terminal when looking in the direction of the airflow. On request, the terminal can be delivered with connections on the left hand side.
- When terminals are ordered with controls, these will be factory fitted, wired and calibrated upon request.



# Induction VAV air volume control terminals

Technical data  
Type (NV.....)

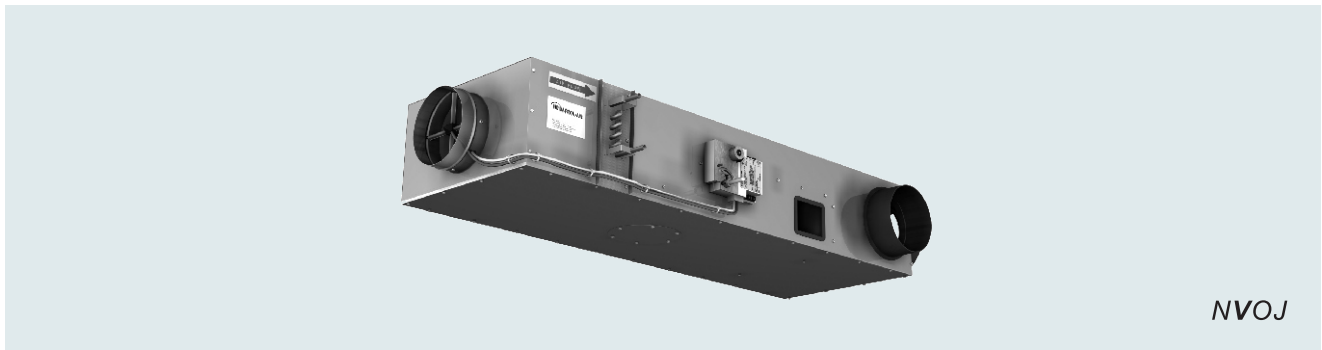

NVOJ

## Specify as:

### Example:

Supply and install, induction variable air volume terminals with distribution plenum with 4 circular outlets, constructed from galvanized sheet steel. The VAV terminals shall have a special 'jet-tronic' low leakage damper blade and an aluminium damper shaft with self lubricating Nylon bearings.

A centre averaging airflow sensor with at least 2 x 12 test points and amplified signal air flow sensor, type Flo-Cross® shall control the airflow with an accuracy not less than 2.5%. The terminals shall be supplied with 1-row hot water reheat coil.

The controller shall be I/A Series, DDC controller:

LonMark compatible, type MNL-V2RVx

or

BACnet, type MNB-V2.

Controls must be factory fitted, wired and calibrated according to the following requirements:

Maximum air volume 250 l/s

Minimum air volume 60 l/s

Minimum air volume 120 l/s (in case of reheat)

Terminal size 200 mm

Max. discharge sound index < NC25 (@250Pa Δp)

Max. radiated sound index < NC25 (@250Pa Δp)

Ordering example: type - model - handing = NVOJA0B - 200R

Manufacturer: HC Barcol-Air

## Installation Instructions:

The HC Barcol-Air VAV terminals shall be installed using at least two support brackets, with anti-vibration rubber under the terminal. Each of these brackets shall be fixed with two threaded rods to the ceiling slab above.

The installation method:

1. Shall prevent the body of the VAV terminal from high mechanical tension, which could damage the construction and performance of the terminal.
2. Shall prevent torsion on the induction VAV terminals, which could cause malfunction of the damper blades.
3. Provides some flexibility to the final location of the VAV terminals.
4. Use at least one diameter straight duct length before the VAV inlet.

5. Additional manual volume control dampers (VCD's) before the unit inlet should not be used.
6. All connections shall be thermally isolated.
7. Pressure sensing tubes of FloCross airflow sensor shall not be "kinked" or otherwise obstructed by the external duct insulation.

See drawing below.

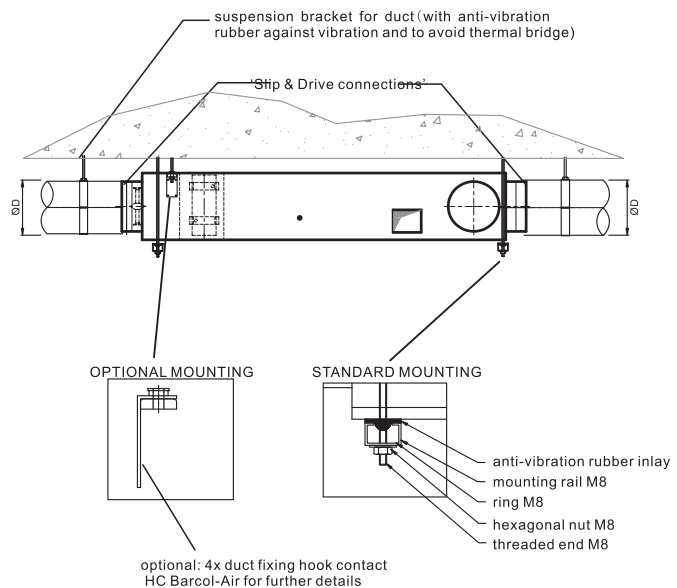

# Induction VAV air volume control terminals

## Model overview Type (NV.....)

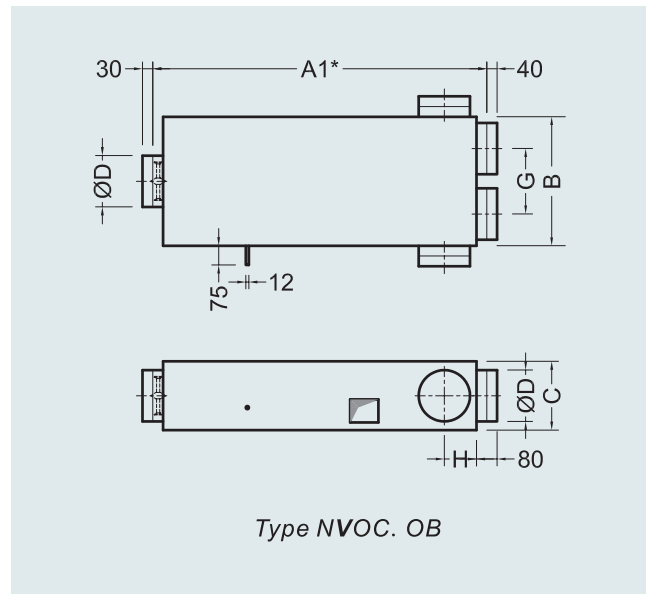
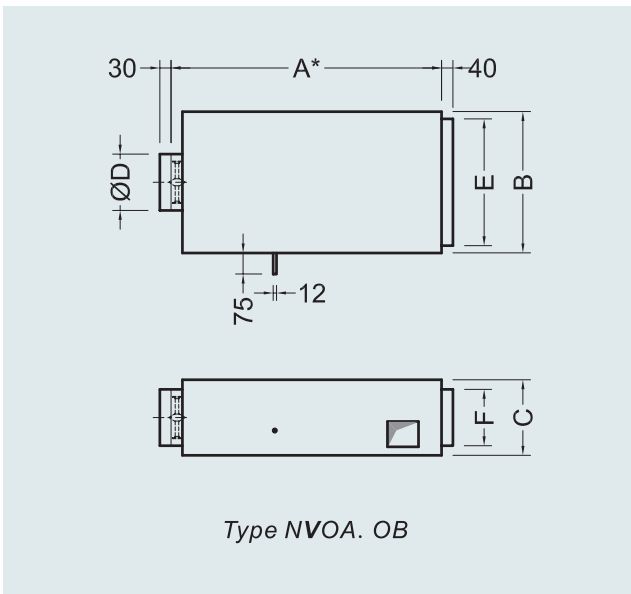
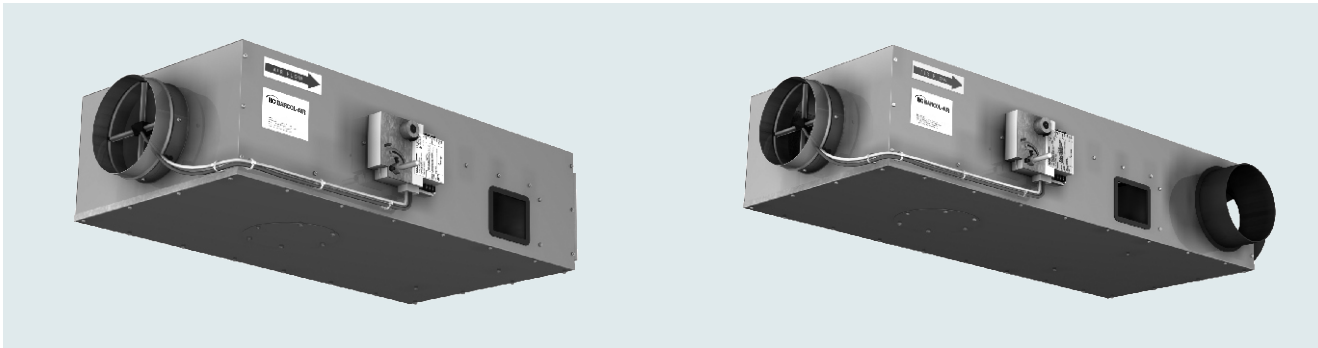

### Dimensions NV

Model	100	125	160	200	250	315	355	400
A	990	990	990	990	990	1540	1540	1540
A1	1300	1300	1300	1300	1400	-	-	-
A2	1240	1240	1240	1240	1240	1790	1790	1790
A3	1550	1550	1550	1550	1750	-	-	-
B	330	330	400	500	600	740	820	910
C	228	228	248	268	318	408	408	458
ØD	98	123	158	198	248	313	353	398
E	275	275	350	450	550	690	770	850
F	170	170	175	200	250	330	330	380
G	180	180	215	255	305	-	-	-
H	125	125	125	125	175	-	-	-

All dimensions in mm.  
 \* = Installed length.  
 \*\* = Size varies with a 1-2-row or 4-row hot water reheat coil.

Other dimensions are available upon request.  
 Size 250 is maximum size for terminals with multiple outlet section.

### Kv values

Model	100	125	160	200	250	315	355	400
Kv (l/s / Pa)	5.5	8.5	15.0	24.9	35.4	58.9	74.3	92.6

Flow = Kv x  $\sqrt{\Delta P_{fc}}$   
 $\Delta P_{fc}$  = Flo-Cross signal  
 If  $\Delta P_{fc}$  = 30 Pa and VAV size = 160  
 Flow = 15.0 x  $\sqrt{30}$  = 82 l/s

# Induction VAV air volume control terminals

## Model overview Type (NV.....)

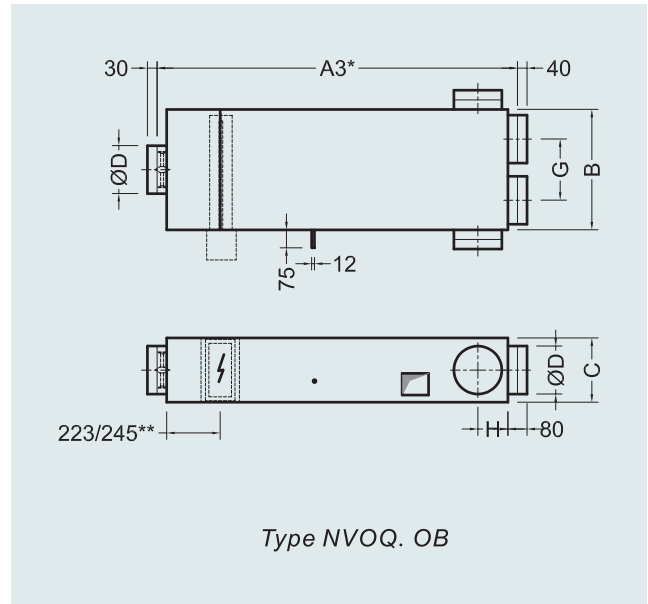
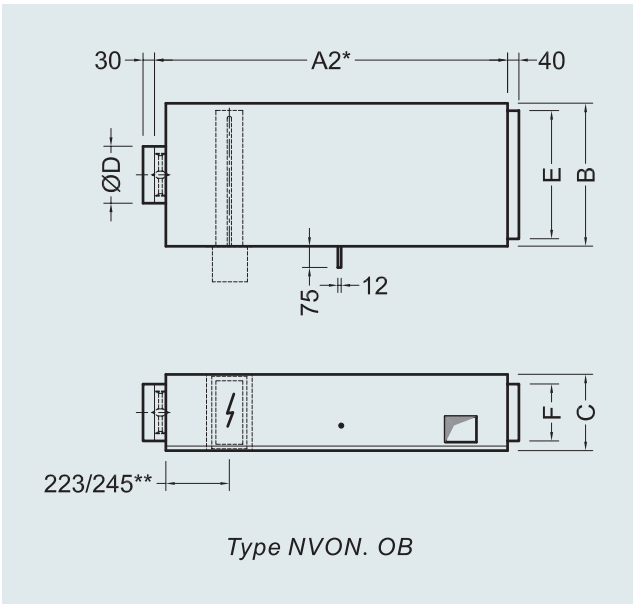
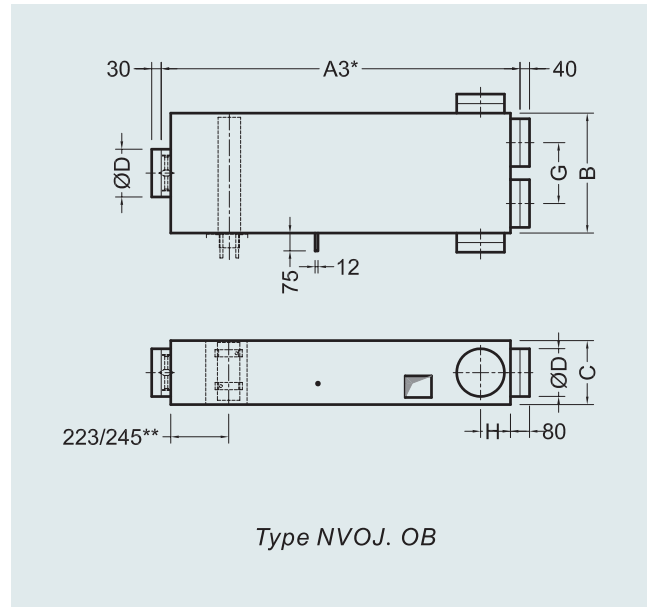
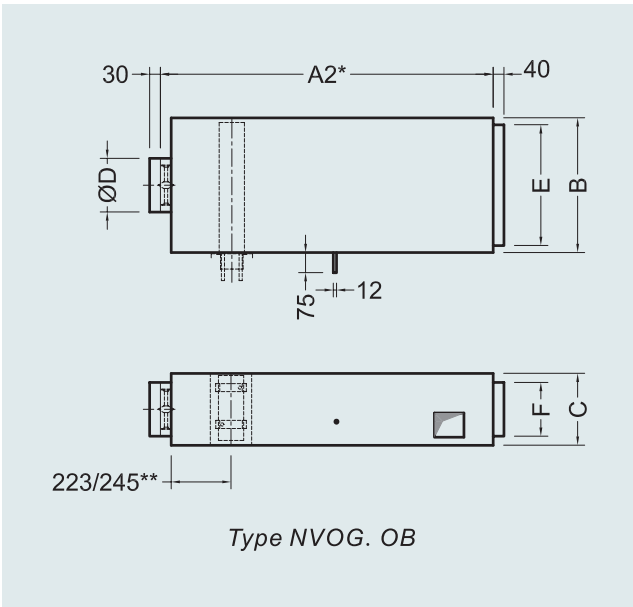
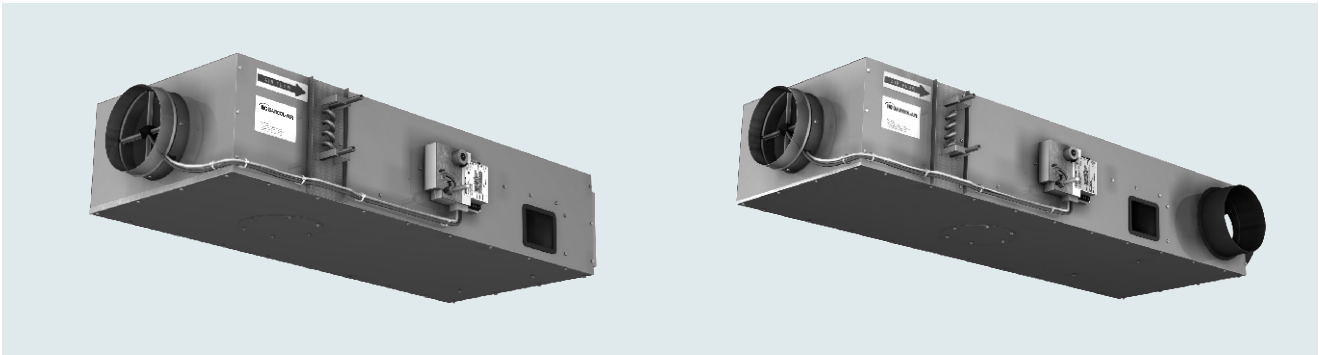

For dimensions see page 4



# Induction VAV air volume control terminals

Type (NVOAOOB)



Sound data  $\Delta p = 250$  Pa

Model	data referring to inlet spigot		$\Delta p = 250$ Pa																					
			discharge sound									radiated sound												
	velocity		air volume		$L_w$ in dB/Oct. (re 1pW)						Lp values			$L_w$ in dB/Oct. (re 1pW)						Lp values				
					125 Hz	250 Hz	500 Hz	1000 Hz	2000 Hz	4000 Hz	dB (A)	NC	NR	125 Hz	250 Hz	500 Hz	1000 Hz	2000 Hz	4000 Hz	dB (A)	NC	NR		
m/s	l/s	CFM	m <sup>3</sup> /h	dB									dB											
100	2	15	31	53	18	28	25	20	20	-	--	--	--	28	29	20	18	-	-	--	--	--		
	4	29	62	106	28	36	33	28	27	20	--	--	--	34	35	26	24	20	-	--	--	--		
	6	44	94	160	33	41	38	33	32	24	--	--	--	37	38	31	29	24	-	--	--	--		
	8	59	125	213	38	44	41	36	35	27	--	--	--	40	41	34	32	27	20	--	--	--		
	10	74	156	266	41	46	44	39	37	29	--	--	--	42	43	36	35	30	23	22	--	--		
125	2	23	49	84	24	32	29	24	24	-	--	--	--	31	32	23	20	-	-	--	--	--		
	4	47	99	168	34	40	37	32	31	23	--	--	--	37	38	29	26	22	-	--	--	--		
	6	70	149	253	39	44	41	37	35	27	--	--	--	40	41	33	31	26	19	--	--	--		
	8	94	198	337	43	48	45	40	38	30	20	--	--	43	44	37	34	29	22	22	--	--		
	10	117	248	421	46	50	47	43	40	32	23	--	--	45	46	39	37	32	25	24	--	21		
160	2	39	82	139	32	36	32	28	27	20	--	--	--	34	30	26	22	18	-	--	--	--		
	4	78	164	279	41	44	40	36	34	27	--	--	--	40	36	33	29	25	17	--	--	--		
	6	116	246	418	46	49	45	41	38	31	22	--	--	43	39	37	33	29	21	20	--	--		
	8	155	328	558	50	52	48	44	41	34	25	--	22	46	42	40	36	32	24	23	--	--		
	10	194	410	697	52	55	51	47	453	36	28	22	25	48	44	43	39	34	27	25	--	--		
200	2	61	129	219	36	39	33	30	28	20	--	--	--	43	38	32	24	20	-	--	--	--		
	4	122	258	439	44	47	41	38	35	27	--	--	--	49	44	38	31	26	19	24	--	--		
	6	183	387	658	49	52	46	42	39	31	25	--	22	52	47	43	35	30	23	28	--	22		
	8	244	516	878	53	55	49	46	42	34	28	23	25	55	50	46	38	34	26	30	22	25		
	10	305	645	1097	55	58	51	48	44	36	31	26	28	57	52	48	41	36	29	33	25	27		
250	2	96	203	345	41	42	35	31	29	20	--	--	--	46	41	35	26	22	-	21	--	--		
	4	192	406	690	48	50	43	39	36	27	23	--	--	52	47	41	33	28	21	27	--	21		
	6	288	609	1035	52	55	48	44	41	31	28	22	25	55	50	45	37	32	25	31	23	25		
	8	383	812	1380	56	58	51	47	43	34	31	26	28	58	53	49	40	36	28	33	26	28		
	10	479	1015	1725	58	61	54	50	46	37	33	29	31	60	55	51	43	38	31	36	29	30		
315	2	153	324	550	46	46	38	33	31	21	--	--	--	49	44	38	28	24	-	24	--	--		
	4	306	648	1101	52	54	46	41	38	28	21	23	55	50	44	35	30	23	30	22	24	--		
	6	459	971	1651	53	58	51	46	42	32	31	26	28	58	53	48	39	34	27	33	26	28		
	8	612	1295	2202	58	62	54	49	45	35	34	30	32	61	56	52	42	38	30	36	30	31		
	10	764	1619	2752	61	64	56	52	47	37	37	33	35	63	58	54	45	40	33	39	32	33		
355	2	195	412	701	48	48	39	34	31	21	--	--	--	51	46	39	29	25	18	26	--	20		
	4	389	824	1401	54	56	47	42	38	28	23	25	56	51	46	36	32	24	31	24	26	--		
	6	584	1236	2102	58	60	52	47	43	32	33	28	31	60	55	50	40	36	28	35	28	30		
	8	779	1649	2803	60	64	55	50	45	35	36	32	34	62	57	53	43	39	31	38	31	33		
	10	973	2061	3503	62	66	58	53	48	37	38	35	37	65	60	56	46	41	34	40	34	35		
400	2	248	524	891	51	50	41	35	32	21	24	--	--	52	47	41	30	26	19	27	--	22		
	4	495	1049	1783	56	58	49	43	39	28	30	25	28	58	53	47	37	33	25	33	26	28		
	6	743	1573	2674	59	62	54	48	43	32	35	31	33	61	56	51	41	37	29	37	30	31		
	8	990	2097	3565	61	66	57	51	46	35	38	35	36	64	59	55	44	40	32	39	33	34		
	10	1238	2621	4456	63	68	60	54	48	38	40	38	39	66	61	57	47	42	35	42	36	37		

- Sound data is determined in a reverberation room at an independent sound laboratory, according to ISO3741 and ISO 5135 standards.
- $L_w$  in dB/Oct. (re 1pW) are sound power levels for discharge sound and case radiated sound. Figures less than 17 dB are indicated by "-".
- The discharge sound pressure levels are determined with the assumptions as mentioned in table 1 for downstream ductwork including a diffuser with insulated plenum box.
- The radiated sound pressure levels are determined with the assumptions as mentioned in table 1 for ceiling plenum and suspended ceiling absorption.

- Lp values are including a room absorption of 10 dB/Oct.
- DB(A), NC and NR index figures are sound pressure levels. Figures less than 20 are indicated by "-".
- $\Delta p$ s is static pressure drop across VAV air volume control terminal with damper fully open.
- For non standard applications and/or selections, please contact our technical staff.

Table 1 : Assumptions for additional attenuation

Hz	125	250	500	1K	2K	4K
Discharge (dB)	5	10	20	30	30	25
Radiated (dB)	2	5	10	15	15	20

Table 2 : Insertion Loss

Model	125	250	500	1K	2K	4K	Hz
100	7	11	16	22	23	22	dB
125	5	10	14	21	22	20	dB
160	4	7	11	15	16	15	dB
200	4	6	9	13	14	13	dB
250	3	6	8	12	13	12	dB
315	3	5	8	11	12	12	dB
355	3	4	7	10	11	12	dB
400	3	4	6	10	11	12	dB



# Induction VAV air volume control terminals

Type (NVOCO0B)



Sound data  $\Delta p = 150 \text{ Pa}$

Model	data referring to inlet spigot		$\Delta p = 150 \text{ Pa}$																			
			discharge sound						Lp values			radiated sound										
			L <sub>w</sub> in dB/Oct. (re 1pW)									L <sub>w</sub> in dB/Oct. (re 1pW)										
	velocity	air volume			125 Hz	250 Hz	500 Hz	1000 Hz	2000 Hz	4000 Hz	dB (A)	NC	NR	125 Hz	250 Hz	500 Hz	1000 Hz	2000 Hz	4000 Hz	dB (A)	NC	NR
m/s	l/s	CFM	m <sup>3</sup> /h	dB									dB									
100	2	15	31	53	-	18	-	-	-	-	--	--	25	26	-	-	-	-	--	--	--	
	4	29	62	106	19	26	21	-	-	-	--	--	30	31	22	20	-	-	--	--	--	
	6	44	94	160	25	30	26	19	-	-	--	--	34	35	26	24	20	-	--	--	--	
	8	59	125	213	29	34	29	22	18	-	--	--	37	38	30	28	24	-	--	--	--	
	10	74	156	266	32	36	32	25	20	-	--	--	39	40	33	31	27	19	--	--	--	
125	2	23	49	84	-	22	-	-	-	-	--	--	27	28	18	-	-	-	--	--	--	
	4	47	99	168	25	30	24	18	-	-	--	--	33	34	25	22	18	-	--	--	--	
	6	70	149	253	31	34	29	23	18	-	--	--	37	38	29	26	22	-	--	--	--	
	8	94	198	337	35	38	32	26	21	-	--	--	40	41	33	30	26	18	--	--	--	
	10	117	248	421	38	40	35	29	23	-	--	--	42	43	36	33	29	21	21	--	--	--
160	2	39	82	139	23	26	20	-	-	-	--	--	31	27	21	-	-	-	--	--	--	
	4	78	164	279	32	34	28	22	17	-	--	--	36	32	28	24	20	-	--	--	--	
	6	116	246	418	37	39	33	27	21	-	--	--	40	36	32	29	4	17	--	--	--	
	8	155	328	558	41	42	36	30	24	-	--	--	43	39	36	32	28	20	--	--	--	
	10	194	410	697	44	45	39	33	27	18	--	--	45	41	39	35	31	23	22	--	--	--
200	2	61	129	219	27	29	21	-	-	-	--	--	40	35	27	19	-	-	--	--	--	
	4	122	258	439	36	37	29	23	19	-	--	--	45	40	34	26	22	-	20	--	--	
	6	183	387	658	40	42	33	28	23	-	--	--	49	44	38	31	26	19	24	--	--	
	8	244	516	878	44	45	37	31	26	-	--	--	52	47	42	34	30	22	27	--	21	
	10	305	645	1097	47	48	39	34	28	18	21	--	--	54	49	45	37	33	25	30	21	24
250	2	96	203	345	32	32	23	17	-	-	--	--	42	37	30	21	18	-	--	--	--	
	4	192	406	690	39	40	31	25	20	-	--	--	48	43	37	28	24	-	23	--	--	
	6	288	609	1035	44	45	36	30	24	-	--	--	52	47	41	32	28	21	27	--	21	
	8	383	812	1380	47	48	39	33	27	-	21	--	--	55	50	45	36	32	24	30	22	24
	10	479	1015	1725	49	51	42	36	29	19	23	--	20	57	52	48	39	35	27	33	25	27
315	2	153	324	550	37	36	26	19	-	-	--	--	45	40	33	23	20	-	20	--	--	
	4	306	648	1101	43	44	34	27	21	-	--	--	51	46	40	30	26	19	26	--	20	
	6	459	971	1651	47	48	38	32	25	-	21	--	--	55	50	44	35	30	23	30	22	24
	8	612	1295	2202	50	52	42	35	28	-	24	--	21	58	53	48	38	34	26	33	25	27
	10	764	1619	2752	52	54	44	38	30	19	27	21	24	60	55	51	41	37	29	35	29	30
355	2	195	412	701	40	37	27	20	-	-	--	--	47	42	25	24	21	-	22	--	--	
	4	389	824	1401	45	45	35	28	22	-	--	--	53	48	41	31	27	20	28	--	22	
	6	584	1236	2102	49	50	40	33	26	-	23	--	--	56	51	46	36	31	24	31	24	26
	8	779	1649	2803	51	53	43	36	29	17	26	20	23	59	54	49	39	35	27	34	27	29
	10	973	2061	3503	53	56	46	39	31	19	28	23	26	62	57	52	42	38	30	37	31	32
400	2	248	524	891	43	39	29	21	-	-	--	--	48	43	36	25	22	-	23	--	--	
	4	495	1049	1783	48	47	37	29	23	-	21	--	--	54	49	43	32	28	21	29	21	24
	6	743	1573	2674	51	52	41	34	27	-	25	--	22	58	53	47	37	32	25	33	26	28
	8	990	2097	3565	53	55	45	37	30	17	28	23	25	61	56	51	40	36	28	36	29	31
	10	1238	2621	4456	54	58	47	39	32	20	30	26	28	63	58	54	43	39	31	38	32	33

- Sound data is determined in a reverberation room at an independent sound laboratory, according to ISO3741 and ISO 5135 standards.
- L<sub>w</sub> in dB/Oct. (re 1pW) are sound power levels for discharge sound and case radiated sound. Figures less than 17 dB are indicated by "-".
- The discharge sound pressure levels are determined with the assumptions as mentioned in table 1 for downstream ductwork including a diffuser with insulated plenum box.
- The radiated sound pressure levels are determined with the assumptions as mentioned in table 1 for ceiling plenum and suspended ceiling absorption.

- Lp values are including a room absorption of 10 dB/Oct.
- DB(A), NC and NR index figures are sound pressure levels. Figures less than 20 are indicated by "-".
- $\Delta p$ s is static pressure drop across VAV air volume control terminal with damper fully open.
- For non standard applications and/or selections, please contact our technical staff.

Table 1 : Assumptions for additional attenuation

Hz	125	250	500	1K	2K	4K
Discharge (dB)	5	10	20	30	30	25
Radiated (dB)	2	5	10	15	15	20

Table 2 : Insertion Loss

规格	125	250	500	1K	2K	4K	Hz
100	13	18	24	32	35	34	dB
125	11	17	22	31	34	32	dB
160	10	14	19	25	28	27	dB
200	10	13	17	23	26	25	dB
250	9	13	16	22	25	24	dB
315	9	12	16	21	24	24	dB
355	9	12	16	21	24	24	dB
400	8	11	13	19	22	23	dB



# Induction VAV air volume control terminals

Type NVOG. OB NVON. OB



Sound data  $\Delta p = 150$  Pa

Model	data referring to inlet spigot		$\Delta p = 150$ Pa																			
			discharge sound						Lp values			radiated sound						Lp values				
	velocity	air volume			L <sub>w</sub> in dB/Oct. (re 1pW)						dB(A)	NC	NR	L <sub>w</sub> in dB/Oct. (re 1pW)						dB(A)	NC	NR
					125 Hz	250 Hz	500 Hz	1000 Hz	2000 Hz	4000 Hz				125 Hz	250 Hz	500 Hz	1000 Hz	2000 Hz	4000 Hz			
m/s	l/s	CFM	m <sup>3</sup> /h	dB						dB												
100	2	15	31	53	-	25	21	-	-	-	--	--	--	25	26	-	-	-	-	--	--	--
	4	29	62	106	25	33	29	24	23	-	--	--	--	30	31	22	20	-	-	--	--	--
	6	44	94	160	31	37	34	29	27	18	--	--	--	34	35	26	24	20	-	--	--	--
	8	59	125	213	35	41	37	32	30	21	--	--	--	37	38	30	28	24	-	--	--	--
	10	74	156	266	38	43	40	35	32	23	--	--	--	39	40	33	31	27	19	--	--	--
125	2	23	49	84	21	29	24	20	19	-	--	--	--	27	28	18	-	-	-	--	--	--
	4	47	99	168	31	37	32	28	26	17	--	--	--	33	34	25	22	18	-	--	--	--
	6	70	149	253	37	41	37	33	30	21	--	--	--	37	38	29	26	22	-	--	--	--
	8	94	198	337	41	45	40	36	33	24	--	--	--	40	41	33	30	26	18	--	--	--
	10	117	248	421	44	47	43	39	35	26	--	--	--	42	43	36	33	29	21	21	--	--
160	2	39	82	139	29	33	28	24	22	-	--	--	--	31	27	21	-	-	-	--	--	--
	4	78	164	279	38	41	36	32	29	21	--	--	--	36	32	28	24	20	-	--	--	--
	6	116	246	418	43	46	41	37	33	25	--	--	--	40	36	32	29	24	17	--	--	--
	8	155	328	558	47	49	44	40	36	28	22	--	22	43	39	36	32	28	20	--	--	--
	10	194	410	697	50	52	47	43	39	30	25	--	25	45	41	39	35	31	23	22	--	--
200	2	61	129	219	33	36	29	25	23	-	--	--	--	40	35	27	19	-	-	--	--	--
	4	122	258	439	42	44	37	33	31	21	--	--	--	45	40	34	26	22	-	20	--	--
	6	183	387	658	46	49	41	38	35	25	21	--	22	49	44	38	31	26	19	24	--	--
	8	244	516	878	50	52	45	41	38	28	25	--	25	52	47	42	34	30	22	27	--	21
	10	305	645	1097	53	55	47	44	40	30	27	22	28	54	49	45	37	33	25	30	21	24
250	2	96	203	345	38	39	31	27	25	-	--	--	--	42	37	30	21	18	-	--	--	--
	4	192	406	690	45	47	39	35	32	21	--	--	--	48	43	37	28	24	-	23	--	--
	6	288	609	1035	50	52	44	40	36	25	24	--	25	52	47	41	32	28	21	27	--	21
	8	383	812	1380	53	55	47	43	39	28	28	22	28	55	50	45	36	32	24	30	22	24
	10	479	1015	1725	55	58	50	46	41	30	30	25	31	57	52	48	39	35	27	33	25	27
315	2	153	324	550	43	43	34	29	26	-	--	--	--	45	40	33	23	20	-	20	--	--
	4	306	648	1101	49	51	42	37	33	22	23	21	--	51	46	40	30	26	19	26	--	20
	6	459	971	1651	53	55	46	42	37	26	28	26	22	55	50	44	35	30	23	30	22	24
	8	612	1295	2202	56	59	50	45	40	29	31	30	26	58	53	48	38	34	26	33	25	27
	10	764	1619	2752	58	61	52	48	42	31	33	33	29	60	55	51	41	37	29	35	29	30
355	2	195	412	701	46	44	35	30	27	-	--	--	--	47	42	35	24	21	-	22	--	--
	4	389	824	1401	51	52	43	38	34	22	25	23	--	53	48	41	31	27	20	28	--	22
	6	584	1236	2102	55	57	48	43	38	26	30	28	25	56	51	46	36	31	24	31	24	26
	8	779	1649	2803	57	60	51	46	41	29	33	32	28	59	54	49	39	35	27	34	27	29
	10	973	2061	3503	59	63	54	49	43	31	35	35	31	62	57	52	42	38	30	37	31	32
400	2	248	524	891	49	46	37	31	28	-	21	--	--	48	43	36	25	22	-	23	-	--
	4	495	1049	1783	54	54	45	39	35	22	27	25	21	54	49	43	32	28	21	29	21	24
	6	743	1573	2674	57	59	49	44	39	27	32	31	27	58	53	47	37	32	25	33	26	28
	8	990	2097	3565	59	62	53	47	42	29	35	35	31	61	56	51	40	36	28	36	29	31
	10	1238	2621	4456	60	65	55	49	44	32	37	38	34	63	58	54	43	39	31	38	32	33

- Sound data is determined in a reverberation room at an independent sound laboratory, according to ISO3741 and ISO 5135 standards.
- L<sub>w</sub> in dB/Oct. (re 1pW) are sound power levels for discharge sound and case radiated sound. Figures less than 17 dB are indicated by "-".
- The discharge sound pressure levels are determined with the assumptions as mentioned in table 1 for downstream ductwork including a diffuser with insulated plenum box.
- The radiated sound pressure levels are determined with the assumptions as mentioned in table 1 for ceiling plenum and suspended ceiling absorption.

- Lp values are including a room absorption of 10 dB/Oct.
- DB(A), NC and NR index figures are sound pressure levels. Figures less than 20 are indicated by "-".
- $\Delta p$ s is static pressure drop across VAV air volume control terminal with damper fully open.
- For non standard applications and/or selections, please contact our technical staff.

Table 1 : Assumptions for additional attenuation

Hz	125	250	500	1K	2K	4K
Discharge (dB)	5	10	20	30	30	25
Radiated (dB)	2	5	10	15	15	20

Table 2 : Insertion Loss

规格	125	250	500	1K	2K	4K	Hz
100	7	11	16	22	23	22	dB
125	5	10	14	21	22	20	dB
160	4	7	11	15	16	15	dB
200	4	6	9	13	14	13	dB
250	3	6	8	12	13	12	dB
315	3	5	8	11	12	12	dB
355	3	4	7	10	11	12	dB
400	3	4	6	10	11	12	dB



# Induction VAV air volume control terminals

Type NVOG. OB NVON. OB

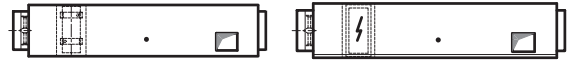

Sound data  $\Delta p = 250 \text{ Pa}$

Model	data referring to inlet spigot				$\Delta p = 250 \text{ Pa}$																	
					discharge sound							radiated sound										
	air volume				$L_w$ in dB/Oct. (re 1pW)						Lp values			$L_w$ in dB/Oct. (re 1pW)						Lp values		
					125 Hz	250 Hz	500 Hz	1000 Hz	2000 Hz	4000 Hz	dB (A)	NC	NR	125 Hz	250 Hz	500 Hz	1000 Hz	2000 Hz	4000 Hz	dB (A)	NC	NR
m/s	l/s	CFM	m <sup>3</sup> /h	dB						dB												
100	2	15	31	53	18	28	25	20	20	-	--	--	--	28	29	20	18	-	-	--	--	--
	4	29	62	106	28	36	33	28	27	20	--	--	--	34	35	26	24	20	-	--	--	--
	6	44	94	160	33	41	38	33	32	24	--	--	--	37	38	31	29	24	-	--	--	--
	8	59	125	213	38	44	41	36	35	27	--	--	--	40	41	34	32	27	20	--	--	--
	10	74	156	266	41	46	44	39	37	29	--	--	--	42	43	36	35	30	23	22	--	--
125	2	23	49	84	24	32	29	24	24	-	--	--	--	31	32	23	20	-	-	--	--	--
	4	47	99	168	34	40	37	32	31	23	--	--	--	37	38	29	26	22	-	--	--	--
	6	70	149	253	39	44	41	37	35	27	--	--	--	40	41	33	31	26	19	--	--	--
	8	94	198	337	43	48	45	40	38	30	20	--	--	43	44	37	34	29	22	22	--	--
	10	117	248	421	46	50	47	43	40	32	23	--	--	45	46	39	37	32	25	24	--	21
160	2	39	82	139	32	36	32	28	27	20	--	--	--	34	30	26	22	18	-	--	--	--
	4	78	164	279	41	44	40	36	34	27	--	--	--	40	36	33	29	25	17	--	--	--
	6	116	246	418	46	49	45	41	38	31	22	--	--	43	39	37	33	29	21	22	--	--
	8	155	328	558	50	52	48	44	41	34	25	--	22	46	42	40	36	32	24	23	--	--
	10	194	410	697	52	55	51	47	43	36	28	22	25	48	44	43	39	34	27	25	--	--
200	2	61	129	219	36	39	33	30	28	20	--	--	--	43	38	32	24	20	-	--	--	--
	4	122	258	439	44	47	41	38	35	27	--	--	--	49	44	38	31	26	19	24	--	--
	6	183	387	658	49	52	46	42	39	31	25	--	22	52	47	43	35	30	23	28	--	22
	8	244	516	878	53	55	49	46	42	34	28	23	25	55	50	46	38	34	26	30	22	25
	10	305	645	1097	55	58	51	48	44	36	31	26	28	57	52	48	41	36	29	33	25	27
250	2	96	203	345	41	42	35	31	29	20	--	--	--	46	41	35	26	22	-	21	--	--
	4	192	406	690	48	50	43	39	36	27	23	--	--	52	47	41	33	28	21	27	--	21
	6	288	609	1035	52	55	48	44	41	31	28	22	25	55	50	45	37	32	25	31	23	25
	8	383	812	1380	56	58	51	47	43	34	31	26	28	58	53	49	40	36	28	33	26	28
	10	479	1015	1725	58	61	54	50	46	37	33	29	31	60	55	51	43	38	31	36	29	30
315	2	153	324	550	46	46	38	33	31	21	--	--	--	49	44	38	28	24	-	24	--	--
	4	306	648	1101	52	54	46	41	38	28	21	23	25	55	50	44	35	30	23	30	22	24
	6	459	971	1651	56	58	51	46	42	32	31	26	28	58	53	48	39	34	27	33	26	28
	8	612	1295	2202	58	62	54	49	45	35	34	30	32	61	56	52	42	38	30	36	30	31
	10	764	1619	2752	61	64	56	52	47	37	37	33	35	63	58	54	45	40	33	39	32	33
355	2	195	412	701	48	48	39	34	31	21	21	--	--	51	46	39	29	25	18	26	--	20
	4	389	824	1401	54	56	47	42	38	28	23	25	25	56	51	46	36	32	24	31	24	26
	6	584	1236	2102	58	60	52	47	43	32	33	28	31	60	55	50	40	36	28	35	28	30
	8	779	1649	2803	60	64	55	50	45	35	36	32	34	62	57	53	43	39	31	38	31	33
	10	973	2061	3503	62	66	58	53	48	37	38	35	37	65	60	56	46	41	34	40	34	35
400	2	248	524	891	51	50	41	35	32	21	24	--	--	52	47	41	30	26	19	27	-	22
	4	495	1049	1783	56	58	49	43	39	28	30	25	28	58	53	47	37	33	25	33	26	28
	6	743	1573	2674	59	62	54	48	43	32	35	31	33	61	56	51	41	37	29	37	30	31
	8	990	2097	3565	61	66	57	51	46	35	38	35	36	64	59	55	44	40	32	39	33	34
	10	1238	2621	4456	63	68	60	54	48	38	40	38	39	66	61	57	47	42	35	42	36	37

- Sound data is determined in a reverberation room at an independent sound laboratory, according to ISO3741 and ISO 5135 standards.
- $L_w$  in dB/Oct. (re 1pW) are sound power levels for discharge sound and case radiated sound. Figures less than 17 dB are indicated by "-".
- The discharge sound pressure levels are determined with the assumptions as mentioned in table 1 for downstream ductwork including a diffuser with insulated plenum box.
- The radiated sound pressure levels are determined with the assumptions as mentioned in table 1 for ceiling plenum and suspended ceiling absorption.

- Lp values are including a room absorption of 10 dB/Oct.
- DB(A), NC and NR index figures are sound pressure levels. Figures less than 20 are indicated by "-".
- $\Delta p$ s is static pressure drop across VAV air volume control terminal with damper fully open.
- For non standard applications and/or selections, please contact our technical staff.

Table 1 : Assumptions for additional attenuation

Hz	125	250	500	1K	2K	4K
Discharge (dB)	5	10	20	30	30	25
Radiated (dB)	2	5	10	15	15	20

Table 2 : Insertion Loss

规格	125	250	500	1K	2K	4K	Hz
100	7	11	16	22	23	22	dB
125	5	10	14	21	22	20	dB
160	4	7	11	15	16	15	dB
200	4	6	9	13	14	13	dB
250	3	6	8	12	13	12	dB
315	3	5	8	11	12	12	dB
355	3	4	7	10	11	12	dB
400	3	4	6	10	11	12	dB



# Induction VAV air volume control terminals

Type NVOJ. OB NVOQ. OB

Sound data  $\Delta p = 250$  Pa

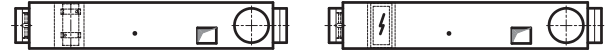

Model	data referring to inlet spigot		$\Delta p = 250$ Pa																																	
			discharge sound						Lp values			radiated sound																								
	velocity		air volume		L <sub>w</sub> in dB/Oct. (re 1pW)						Lp values			L <sub>w</sub> in dB/Oct. (re 1pW)						Lp values																
					125 Hz	250 Hz	500 Hz	1000 Hz	2000 Hz	4000 Hz	dB (A)	NC	NR	125 Hz	250 Hz	500 Hz	1000 Hz	2000 Hz	4000 Hz	dB (A)	NC	NR														
m/s	l/s	CFM	m <sup>3</sup> /h	dB									dB																							
100	2	15	31	53	-	21	17	-	-	-	--	--	--	28	29	20	18	-	-	--	--	--	--	--	--	--	--	--	--	--	--	--	--			
	4	29	62	106	22	29	25	18	-	-	--	--	--	34	35	26	24	20	-	-	--	--	--	--	--	--	--	--	--	--	--	--	--			
	6	44	94	160	27	34	30	23	20	-	--	--	--	37	38	31	29	24	-	-	--	--	--	--	--	--	--	--	--	--	--	--	--			
	8	59	125	213	32	37	33	26	23	-	--	--	--	40	41	34	32	27	20	-	-	--	--	--	--	--	--	--	--	--	--	--	--	--		
	10	74	156	266	35	39	36	29	25	-	--	--	--	42	43	36	35	30	23	-	-	--	--	--	--	--	--	--	--	--	--	--	--	--		
125	2	23	49	84	18	25	21	-	-	-	--	--	--	31	32	23	20	-	-	--	--	--	--	--	--	--	--	--	--	--	--	--	--	--		
	4	47	99	168	28	33	29	22	19	-	--	--	--	37	38	29	26	22	-	-	--	--	--	--	--	--	--	--	--	--	--	--	--	--		
	6	70	149	253	33	37	33	27	23	-	--	--	--	40	41	33	31	26	19	-	-	--	--	--	--	--	--	--	--	--	--	--	--	--		
	8	94	198	337	37	41	37	30	26	18	--	--	--	43	44	37	34	29	22	22	-	-	--	--	--	--	--	--	--	--	--	--	--	--	--	
	10	117	248	421	40	43	39	33	28	20	--	--	--	45	46	39	37	32	25	24	-	-	--	--	--	--	--	--	--	--	21	--	--	--		
160	2	39	82	139	26	29	24	18	-	-	--	--	--	34	30	26	22	18	-	-	--	--	--	--	--	--	--	--	--	--	--	--	--	--	--	
	4	78	164	279	35	37	32	26	22	-	--	--	--	40	36	33	29	25	17	-	-	--	--	--	--	--	--	--	--	--	--	--	--	--	--	
	6	116	246	418	40	42	37	31	26	19	--	--	--	43	39	37	33	29	21	20	-	-	--	--	--	--	--	--	--	--	--	--	--	--	--	--
	8	155	328	558	44	45	40	34	29	22	--	--	--	46	42	40	36	32	24	23	-	-	--	--	--	--	--	--	--	--	--	--	--	--	--	--
	10	194	410	697	46	48	43	37	31	24	21	--	--	--	48	44	43	39	34	27	25	-	-	--	--	--	--	--	--	--	--	--	--	--	--	--
200	2	61	129	219	30	32	25	20	-	-	--	--	--	43	38	32	24	20	-	-	--	--	--	--	--	--	--	--	--	--	--	--	--	--	--	--
	4	122	258	439	38	40	33	28	23	-	--	--	--	49	44	38	31	26	19	24	-	-	--	--	--	--	--	--	--	--	--	--	--	--	--	--
	6	183	387	658	43	45	38	32	27	19	--	--	--	52	47	43	35	30	23	28	-	-	--	--	--	--	--	--	--	--	22	--	--	--	--	
	8	244	516	878	47	48	41	36	30	22	21	--	--	55	50	46	38	34	26	30	22	25	-	-	--	--	--	--	--	25	22	25	25	25	25	
	10	305	645	1097	49	51	43	38	32	24	24	--	--	57	52	48	41	36	29	33	25	27	-	-	--	--	--	--	27	25	27	27	27	27	27	
250	2	96	203	345	35	35	27	21	17	-	--	--	--	46	41	35	26	22	-	-	--	--	--	--	--	--	--	--	--	--	--	--	--	--	--	
	4	192	406	690	42	43	35	29	24	-	--	--	--	52	47	41	33	28	21	27	-	-	--	--	--	--	--	--	--	--	21	--	--	21	21	
	6	288	609	1035	46	48	40	34	29	19	21	--	--	55	50	45	37	32	25	31	23	25	-	-	--	--	--	--	25	23	25	25	25	25	25	
	8	383	812	1380	50	51	43	37	31	22	24	--	21	58	53	49	40	36	28	33	26	28	-	-	--	--	--	--	28	26	28	28	28	28	28	
	10	479	1015	1725	52	54	46	40	34	25	27	21	24	60	55	51	43	38	31	36	29	30	-	-	--	--	--	--	30	29	30	30	30	30	30	
315	2	153	324	550	40	39	30	23	19	-	--	--	--	49	44	38	28	24	-	-	--	--	--	--	--	--	--	--	--	--	--	--	--	--	--	--
	4	306	648	1101	46	47	38	31	26	-	--	--	--	55	50	44	35	30	23	30	22	30	-	-	--	--	--	--	24	22	24	24	24	24	24	
	6	459	971	1651	50	51	43	36	30	20	24	--	21	58	53	48	39	34	27	33	26	28	-	-	--	--	--	--	28	26	28	28	28	28	28	
	8	612	1295	2202	52	55	46	39	33	23	27	22	24	61	56	52	42	38	30	36	30	31	-	-	--	--	--	--	31	30	31	31	31	31	31	31
	10	764	1619	2752	55	57	48	42	35	25	30	25	27	63	58	54	45	40	33	39	32	33	-	-	--	--	--	--	33	32	33	33	33	33	33	33
355	2	195	412	701	42	41	31	24	19	-	--	--	--	51	46	39	29	25	18	26	--	--	--	--	--	--	--	--	--	--	--	--	--	--	--	20
	4	389	824	1401	48	49	39	32	26	-	22	--	--	56	51	46	36	32	24	31	24	26	-	-	--	--	--	--	26	24	26	26	26	26	26	26
	6	584	1236	2102	52	53	44	37	31	20	26	20	23	60	55	50	40	36	28	35	28	30	-	-	--	--	--	--	30	28	30	30	30	30	30	30
	8	779	1649	2803	54	57	47	40	33	23	29	24	27	62	57	53	43	39	31	38	31	33	-	-	--	--	--	--	33	31	33	33	33	33	33	33
	10	973	2061	3503	56	59	50	43	36	25	31	27	29	65	60	56	46	41	34	40	34	35	-	-	--	--	--	--	35	34	35	35	35	35	35	35
400	2	248	524	891	45	43	33	25	20	-	--	--	--	52	47	41	30	26	19	27	--	--	--	--	--	--	--	--	--	--	--	--	--	--	22	
	4	495	1049	1783	50	51	41	33	27	-	24	--	--	58	53	47	37	33	25	33	26	28	-	-	--	--	--	--	28	26	28	28	28	28	28	
	6	743	1573	2674	53	55	46	38	31	20	28	22	25	61	56	51	41	37	29	37	30	31	-	-	--	--	--	--	31	30	31	31	31	31	31	31
	8	990	2097	3565	55	59	49	41	34	23	31	26	29	64	59	55	44	40	32	39	33	34	-	-	--	--	--	--	34	33	34	34	34	34	34	34
	10	1238	2621	4456	57	61	52	44	36	26	33	27	31	66	61	57	47	42	35	42	36	37	-	-	--	--	--	--	37	36	37	37	37	37	37	37

- Sound data is determined in a reverberation room at an independent sound laboratory, according to ISO3741 and ISO 5135 standards.
- L<sub>w</sub> in dB/Oct. (re 1pW) are sound power levels for discharge sound and case radiated sound. Figures less than 17 dB are indicated by "-".
- The discharge sound pressure levels are determined with the assumptions as mentioned in table 1 for downstream ductwork including a diffuser with insulated plenum box.
- The radiated sound pressure levels are determined with the assumptions as mentioned in table 1 for ceiling plenum and suspended ceiling absorption.

- Lp values are including a room absorption of 10 dB/Oct.
- DB(A), NC and NR index figures are sound pressure levels. Figures less than 20 are indicated by "-".
- $\Delta p$ s is static pressure drop across VAV air volume control terminal with damper fully open.
- For non standard applications and/or selections, please contact our technical staff.

Table 1 : Assumptions for additional attenuation

Hz	125	250	500	1K	2K	4K
Discharge (dB)	5	10	20	30	30	25
Radiated (dB)	2	5	10	15	15	20

Table 2 : Insertion Loss

Model	125	250	500	1K	2K	4K	Hz
100	14	20	26	35	38	37	dB
125	12	18	24	34	37	35	dB
160	11	16	21	28	31	30	dB
200	11	15	19	26	29	28	dB
250	10						



**Barcol-Air**

No 16, Changhong Road, Fengxiang Industrial Area,  
Daliang, Shunde, Foshan, Guangdong, China. P. S. : 528300

Tel : 0757-22382867

Fax: 0757-22382857

[www.barcolair.net](http://www.barcolair.net)

[www.barcolair.cn](http://www.barcolair.cn)